

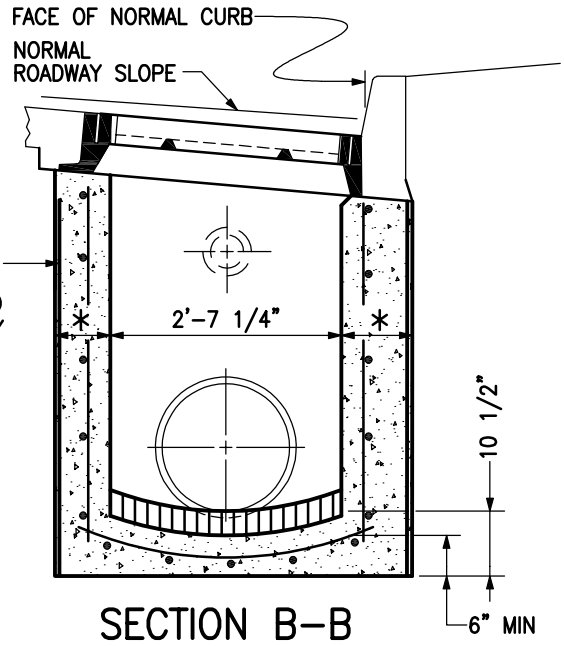

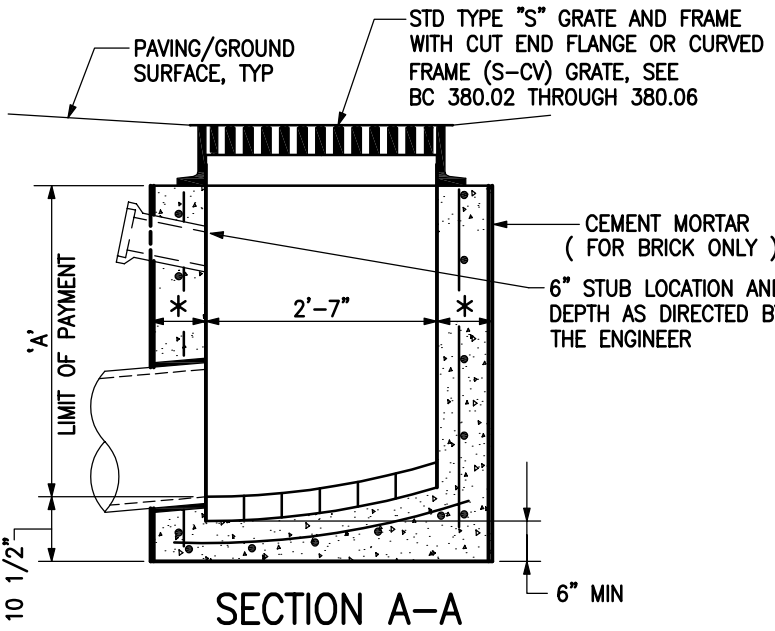

	PRECAST	CAST-IN-PLACE/BRICK
WALL THICKNESS	6" MIN	8 1/2"
REINF	2 LAYERS- 4x4 W4.0 x W4.0- WWF	NO. 4 BARS @ 6" CC EW 2" COVER
CONCRETE	MIX 6	MIX 3
ALLOWABLE DEPTH	DPW APPROVAL REQUIRED OVER 15'	

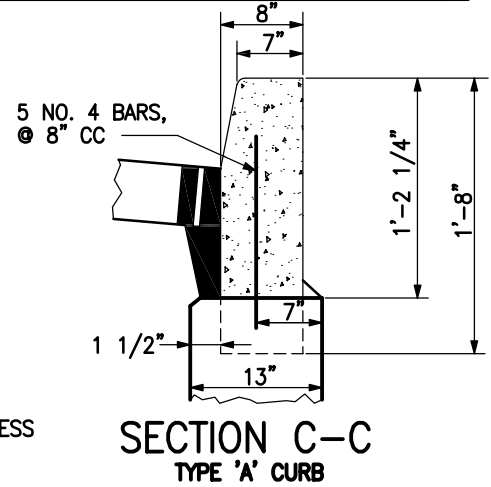
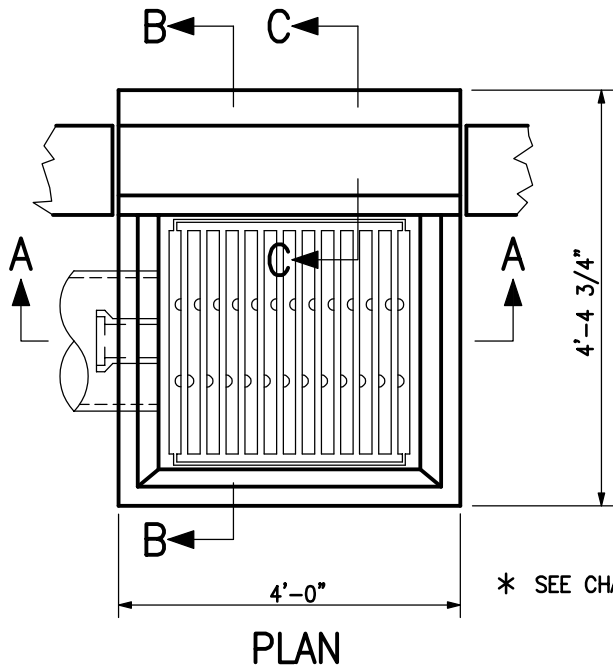

NOTES:

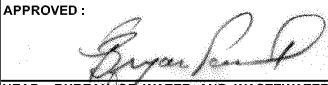
1. INLET MAY BE CONSTRUCTED OF BRICK, CAST IN PLACE OR PRECAST MIX 3 CONCRETE WITH NO. 4 DEFORMED BARS AT 6" CC BOTH WAYS. 2" CLEAR FROM FACE OF INSIDE WALL. SEE LATEST DPW SPECIFICATIONS FOR INLETS.
2. TOP 4" OF PRECAST/CONCRETE WALLS MAY BE BRICK MASONRY TO BRING GRATE TO REQUIRED GRADE.
3. PLACE 1/4" EXPANSION MATERIAL BETWEEN FRAME AND ABUTTING RIGID PAVEMENT; AND BETWEEN ENDS OF INLET CURB AND NORMAL CURB.
4. IF 6" MIX 1 CONCRETE IS USED AS FOUNDATION FOR BRICK INLET, PLACE NO. 4 DEFORMED BARS AT 12" CC BOTH WAYS, 2" CLEAR FROM TOP.
5. COST OF FURNISHING AND PLACING 6" V.P. STUB WITH V.P. STOPPER TO BE INCLUDED IN THE PRICE BID PER LINEAR FOOT OF INLET.
6. DEPTH OF INLET CONNECTION IN STREETS AT CURB LINE TO BE 52" FROM INVERT TO ESTABLISHED CURB GRADE. DEPTH OF INLET CONNECTION IN ALLEYS TO BE 42" FROM INVERT TO ALLEY GRADE. NO DEVIATION FROM THESE DEPTHS WILL BE CONSIDERED FOR PAYMENT UNLESS DIRECTED BY THE ENGINEER IN WRITING.

	APPROVED:  HEAD, BUREAU OF WATER AND WASTEWATER	CITY OF BALTIMORE DEPARTMENT OF PUBLIC WORKS BUREAU OF WATER AND WASTEWATER	ISSUED	REVISED	REVISED
	 DIRECTOR, DEPARTMENT OF PUBLIC WORKS		3 / 2008		
TYPE 'S' INLET SINGLE GRATE			STANDARD NO. BC 380.01		
			SCALE: NONE	SHEET 1 OF 1	