

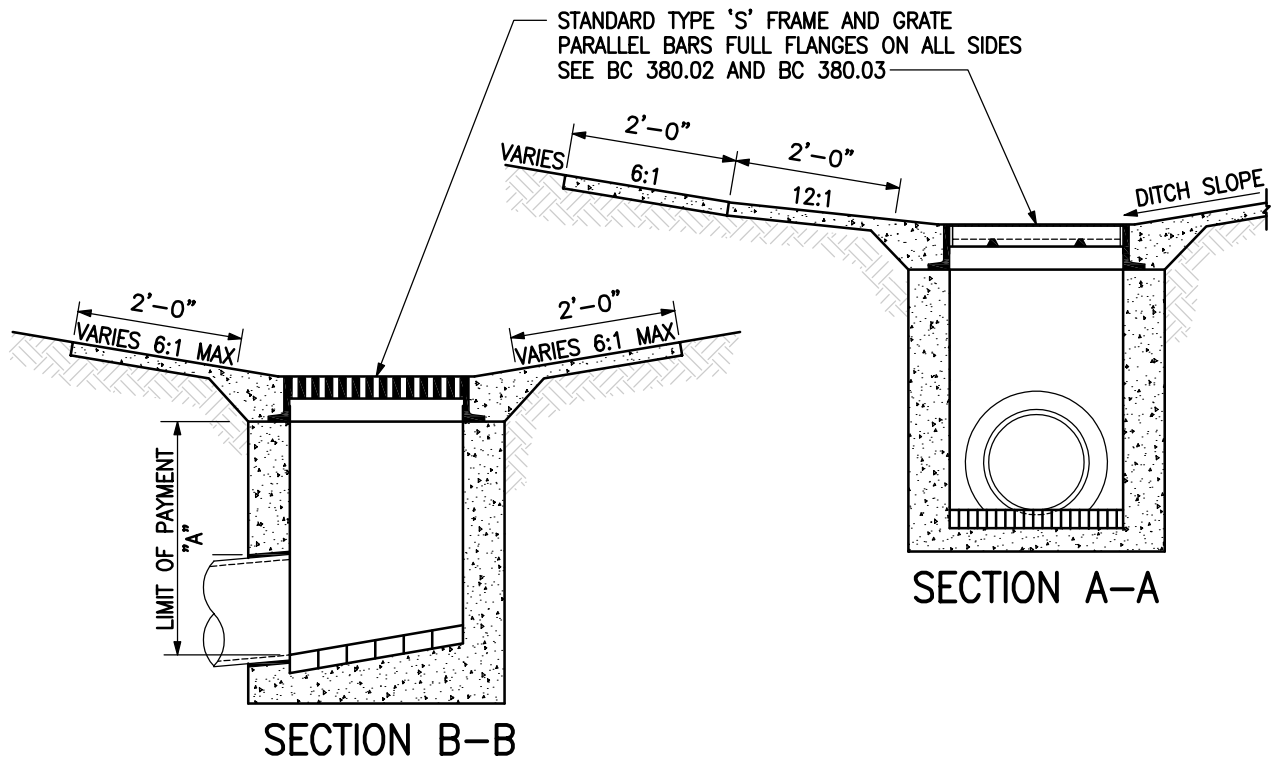



ISOMETRIC VIEW

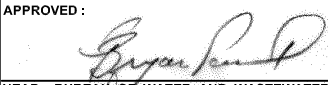

**NOTES:**

1. THE CONCRETE MEDIAN DITCH TO BE USED IN CONNECTION WITH THIS INLET, WILL BE WARPED FROM THE STANDARD SECTION TO MEET THE SECTION AT THE END OF THE INLET. THIS TRANSITION WILL TAKE PLACE WITHIN A DISTANCE OF TEN (10) FEET FROM THE INLET.
2. FOR INLET STRUCTURE SEE BC 380.21

	APPROVED:  HEAD, BUREAU OF WATER AND WASTEWATER	CITY OF BALTIMORE DEPARTMENT OF PUBLIC WORKS BUREAU OF WATER AND WASTEWATER	ISSUED	REVISED	REVISED
	 DIRECTOR, DEPARTMENT OF PUBLIC WORKS		3 / 2008		
TYPE 'S' INLET SINGLE GRATE (DITCH INSTALLATION)			STANDARD NO. BC 380.11		
			SCALE: NONE	SHEET 1 OF 1	