

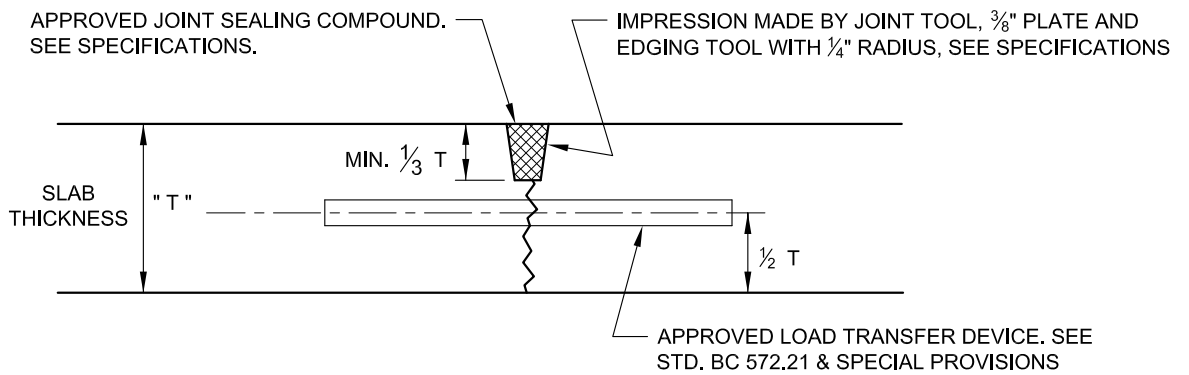

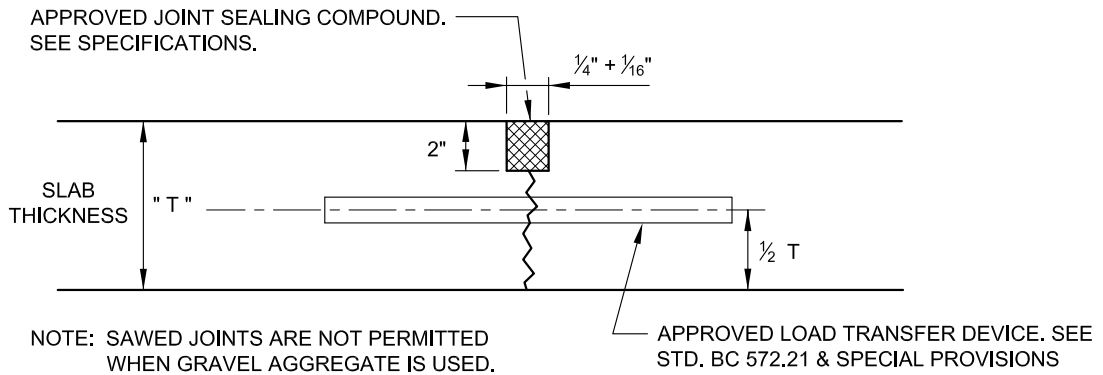

EXPANSION JOINT



TOOLED CONTRACTION JOINT

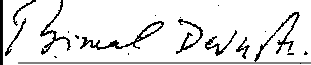

SAWED CONTRACTION JOINT

	APPROVED:  DIVISION CHIEF, TRANSPORTATION ENGINEERING AND CONSTRUCTION  DIRECTOR, DEPARTMENT OF TRANSPORTATION	CITY OF BALTIMORE DEPARTMENT OF TRANSPORTATION TRANSPORTATION ENGINEERING AND CONSTRUCTION			ISSUED	REVISED	REVISED
		TYPES OF JOINTS CEMENT CONCRETE PAVEMENT			8 / 2010		
		STANDARD NO. BC 572.92-1			SCALE : NONE	SHEET 1 OF 2	