

PLAN

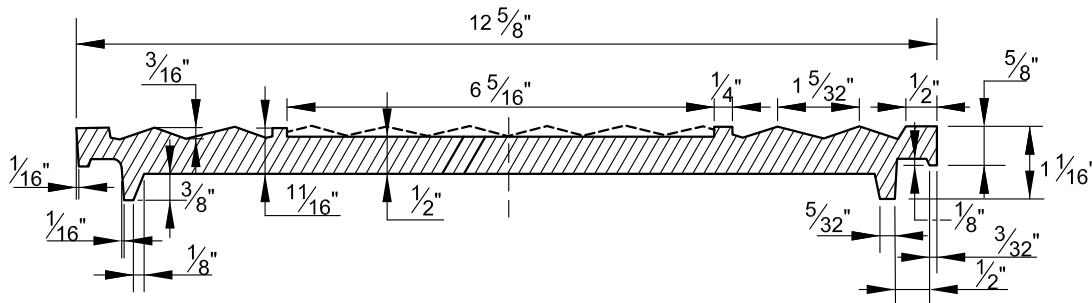

SECTION A-A

NOTE:
HANDBOX COVER MATERIAL SHALL BE CAST STEEL,
21,000 PSI TENSILE STRENGTH. WEIGHT = 21 LBS.

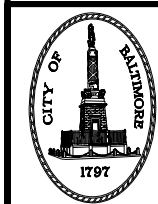

APPROVED:
Primal Devita
DIVISION CHIEF, TRANSPORTATION ENGINEERING
AND CONSTRUCTION
Khalil Zae
DIRECTOR, DEPARTMENT OF TRANSPORTATION

CITY OF BALTIMORE
DEPARTMENT OF TRANSPORTATION
TRANSPORTATION ENGINEERING AND
CONSTRUCTION

STANDARD HANDBOX
COVER - DTT

ISSUED	REVISED	REVISED
8 / 2010		
STANDARD NO. BC 804.09		
SCALE : NONE	SHEET 1 OF 1	