

**Notes:**

1. A cleanout shall be constructed on private property at the property line. A minimum clearance of 2.0 ft. from building structures is required for rodding. If the building's proximity to the property line requires the cleanout to be constructed in the public right of way see BC 830.15.
2. Cleanouts and sanitary connections constructed on private property shall be built under permit and specifications issued by the Department of Housing and Community Development, Plumbing Section.

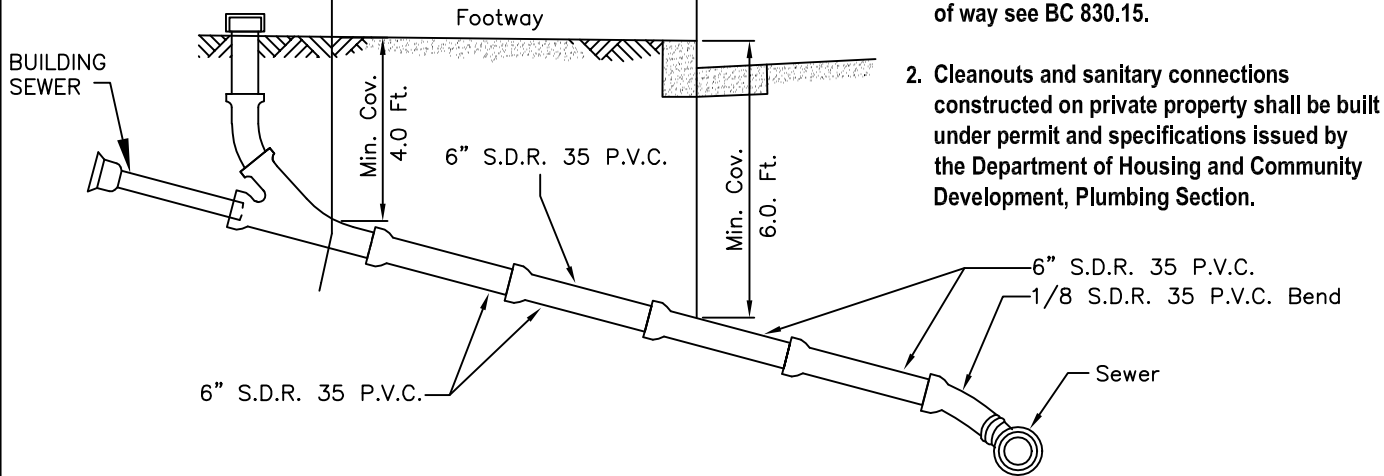

**ELEVATION**

**TYPICAL HOUSE CONNECTION ACROSS FOOTWAYS**

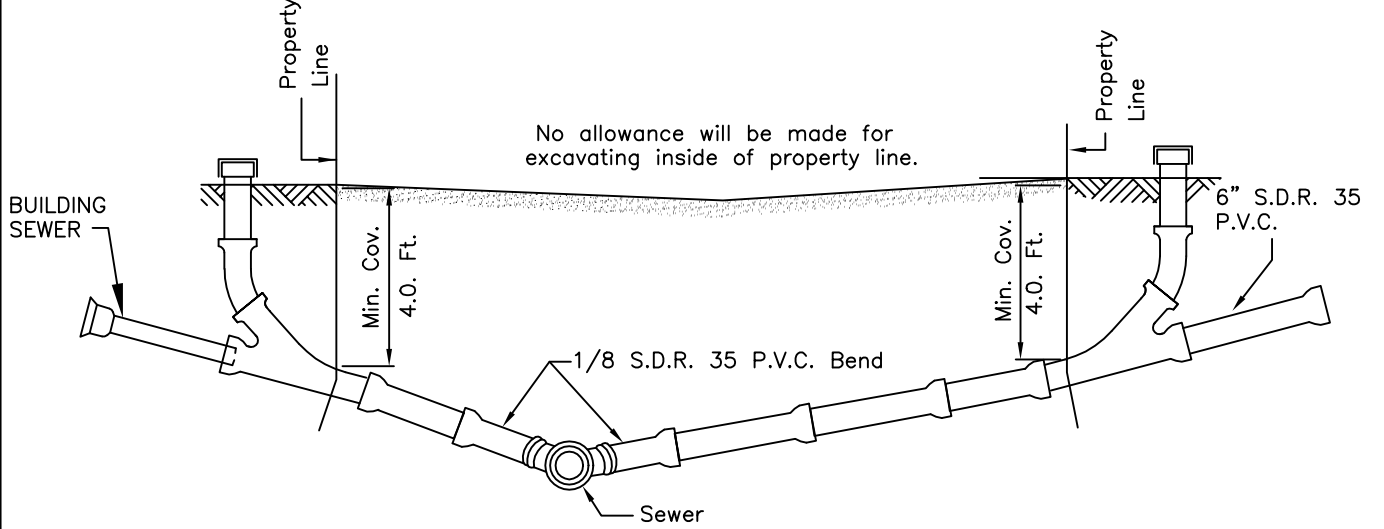

**TYPICAL HOUSE CONNECTION IN ALLEYS**

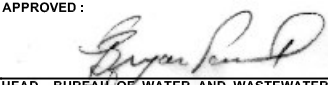
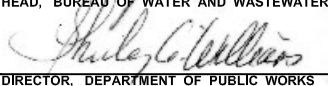
	APPROVED :  HEAD, BUREAU OF WATER AND WASTEWATER	<b>CITY OF BALTIMORE</b> <b>DEPARTMENT OF PUBLIC WORKS</b> <b>BUREAU OF WATER AND WASTEWATER</b>	ISSUED	REVISED	REVISED
	 DIRECTOR, DEPARTMENT OF PUBLIC WORKS		<b>3 / 2008</b>		
	<b>TYPICAL INSTALLATIONS OF SANITARY HOUSE CONNECTIONS</b>			<b>STANDARD NO. BC 830.14</b>	
			SCALE : NONE	SHEET 1 OF 1	